

HV2

DC Voltage Sensor Datasheet



Accuenergy's HV2 Voltage Hall Effect voltage sensor is engineered to measure in high DC voltage in applications where voltages exceed 1000V. With high precision, 0.5% accuracy, the HV2 is an ideal high voltage sensor for single or three-phase inverters, battery charging applications, railway projects, and more.

Features

- Excellent accuracy and good linearity
- Designed for high immunity to external sources of interference
- Wide frequency bandwidth accommodates a variety of applications
- Maintains high performance across a wide temperature range



Accuenergy Inc.

Los Angeles - Toronto - Pretoria
 North America Toll Free: 1-877-721-8908
 Web: www.accuenergy.com
 Email: marketing@accuenergy.com

Revision Date: August 2023 Version: 1.0.1
 Specs Subject To Change Without Notice.



Specifications

HV2-1000, HV2-1200, HV2-1500	
RATED VOLTAGE	1000V, 1200V, 1500V
Voltage Range	10-120% of rated voltage
Output	0-5Vdc
Accuracy	0.50%
MECHANICAL/ENVIRONMENTAL	
Form Factor	Surface Mount
Exterior Dimensions	167.0mm x 62.0mm x 91.0mm 6.57" x 2.44" x 3.58"
Case Material	UL 94V-0
Operating Temperature	-45°C to 85°C / -49°F to 185°F
Storage Temperature	-50°C to 90°C / -58°F to 194°F
Operating Humidity	Non-condensing, 0 to 95% RH
Installation Conditions	Indoor Use
ELECTRICAL	
Polarity	Terminal Connection
Phase Orientation	Follow markings on connector
Frequency Range	DC
Power Supply	±15V
SAFETY/COMPLIANCE	
Certifications	RoHS

Dimensions

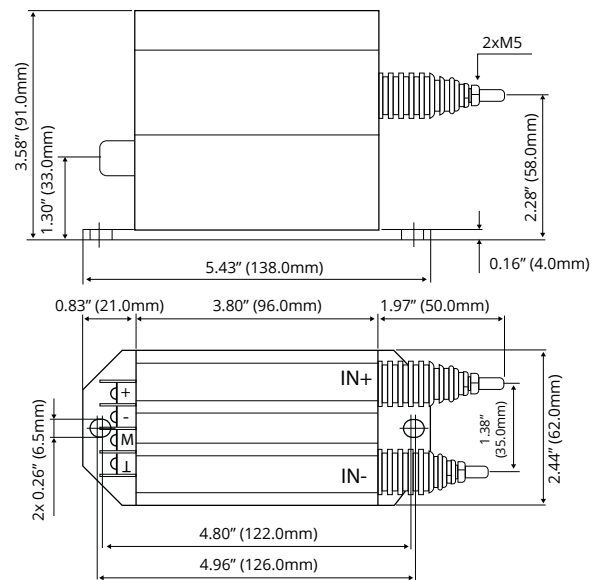

Ordering Information

	Model	Rated Input	Rated Output
Ordering Number	-	:	:
Ordering Example	HV2	- 1000	: A3
		1000:1000V	A3: 0-5V
		1200: 1200V	
		1500:1500V	